



CNB-BE5815NVR/BE5815PVR

Weather Proof IR Camera



Features

- 1/3 inch SONY Super HAD CCD
- High Resolution : 550TV Lines
- DC Iris varifocal lens (f=3.8~9.5m F1.2)
- **Built-in IR LED (34EA) & Sensor(1EA)**
- Day&Night (ICR)
- **Super Digital Noise Reduction (SDNR)**
- Electronic sensitivity-up (DSS)
- Auto White Balance
- AGC/BLC/Flickerless (On/Off)
- Min. Illumination : **Day(0.3Lux), Night(0.000Lux,IR LED On)**
- DC12V/AC24V Dual Voltage
- Weather-proof Housing
- Built in Fan/Heater



DIMENSIONS

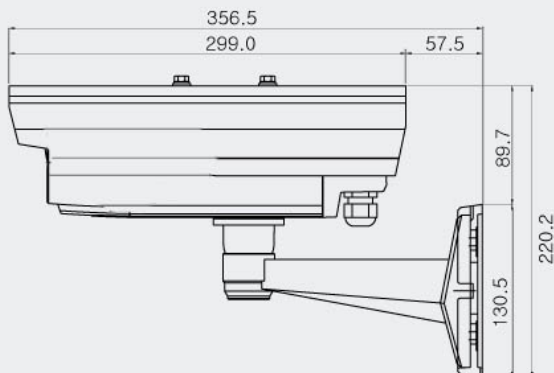
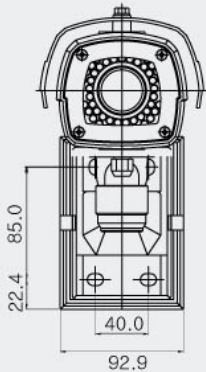

SPECIFICATIONS

Model	CNB-BE5815NVR	CNB-BE5815PVR
Signal System	NTSC	PAL
Scanning System	2:1 Interlace	
Scanning Frequency (H)	15.734 KHz	15.625 KHz
Scanning Frequency (V)	59.94 Hz	50 Hz
Image Sensor	1/3 Inch SONY Super HAD CCD	
Total Pixels	811(H) x 508(V) 410K	795(H) x 596(V) 470K
Total / Effective Pixels	768(H) x 494(V) 380K	752(H) x 582(V) 440K
Horizontal Resolution	550 TV Lines	
Video Output	1.0V p-p (75Ω, Composite)	
S/N Ratio	More than 50dB(AGC Off)	
Lens	DC Iris varifocal Lens (f=3.8~9.5mm F1.2)	
Digital Zoom Ratio	2x (On/Off)	
Min.Illumination	0.3Lux(Color), 0.1Lux(B/W), 0.000Lux (IR LED On)	
IR LED and Sensor	IR LED (850nm, 15°, 30° Mixed) 34EA, Sensor 1EA	
IR LED Visible Range	Max. 30m(Indoor), 20m(Outdoor)	
Day&Night (ICR)	ICR (Sensor Type)	
DSS	On/Off (Max. 32FLD)	
White Balance	Auto	
AGC,BLC, Flickerless	On/Off	
IP Rating	IP65	
Supplied Voltage	DC12V/AC24V Dual Voltage	
Dimensions(WxHxD)	92.9 x 220.2 x 356.5 mm	
Weight	Approx. 3.0 kg	